

Progress on the future DAQ

Matthew Wing - UCL
(on behalf of the CALICE-UK DAQ groups)

Cambridge, Imperial, Manchester, RHUL, UCL

- **Preamble**
- **ASICs and data transportation on the PCBs**
- **Networking and on/off-detector communication**
- **Off-detector receiver**
- **A (paper) model DAQ**

Preamble

Thinking of a future DAQ system, have a conceptual design: commercial, back-planeless, etc.

Basic R&D to investigate issues with this concept. Keep on top of technology.

Idea that it could be used for future detectors (calorimeter) and prototypes.

As well as bench-testing and “generic” R&D, committed to provide DAQ for EUDET module.

Report on progress: model slab and PCI card.

ASIC testing

To test new rounds of ASIC chips for noise, pedestals, etc. and feed back for the next production.

Will do tests of single chips and also many chips.

Expect chip to be fabricated by February 2007.

Continue process for expected rounds of production.

Model slab

Plan

- emulate multiple VFE chips on long PCBs
- study transmission behaviour: noise, cross-talk, etc.
- optimise VFE PCB with respect to data-rate requirements

Needs

- segmented test slab PCBs
- FPGAs emulating VFE chips, “pVFEs”
- FE boards for distribution and reception of clock, controls, data, etc.

Will feed into ASIC and PCB design for EUDET (and final) modules

Will have designed and constructed FE board - feed into future real modules

Model slab layout

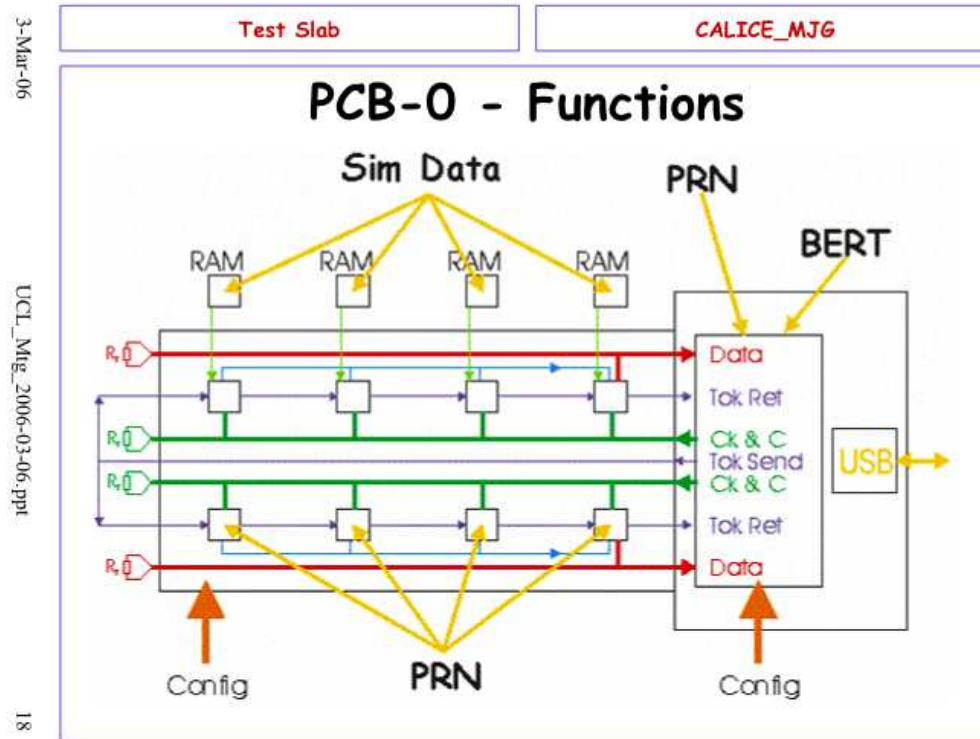

Multiple Test Panels forming a Test Slab

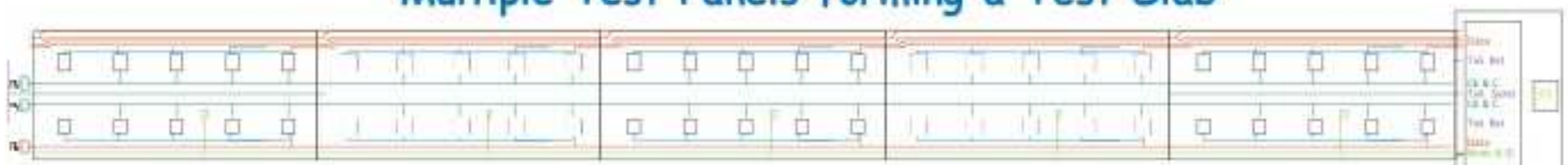

Board design and layout

Assumed:

$5 \times 5 \text{ mm}^2$ pads, 72 channels/ASIC \rightarrow 1 ASIC covers 6×12 pads, or $3 \times 6 \text{ cm}^2$

Thin $64 \mu\text{m}$ layers and narrow $75 \mu\text{m}$ traces

Traces for various clock distribution and/or readout architectures incorporated

Row of 4 FPGAs per board

Every FPGA mimics 2 VFE chips

A row of FPGAs is equivalent to VFE covering $24 \times 6 \text{ cm}^2$

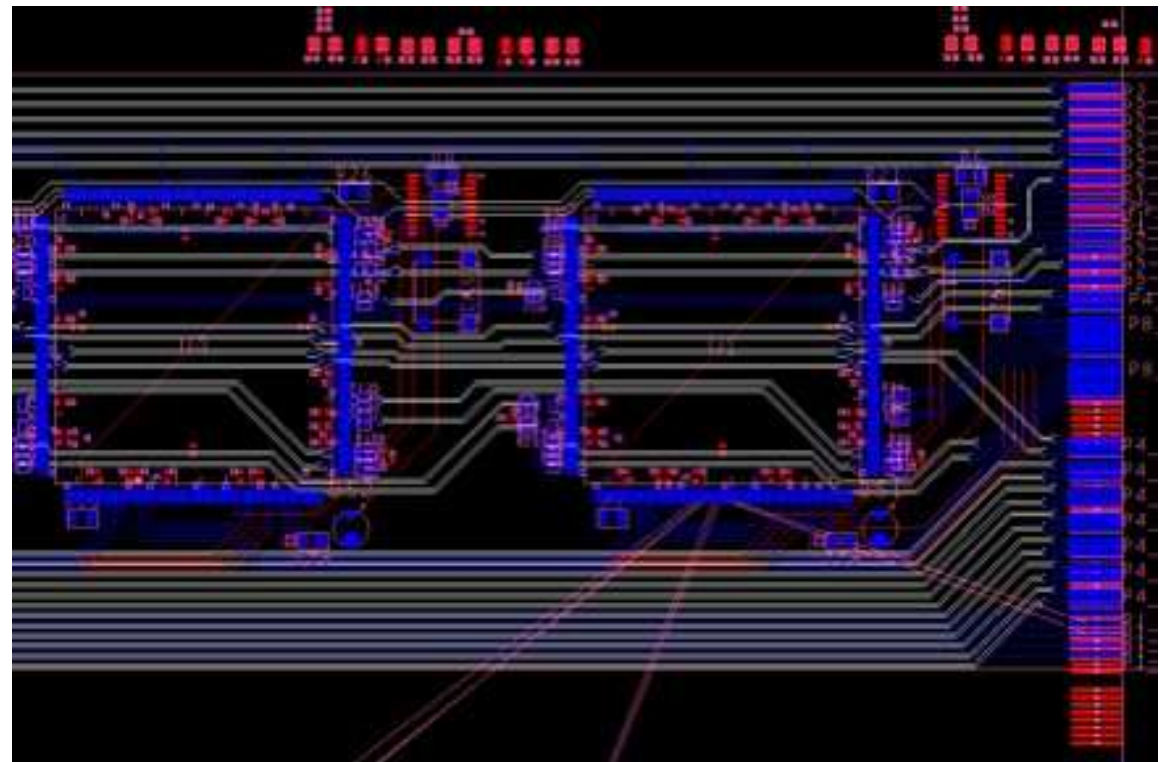

Schematics finished, layout almost finished.

pVFE FPGA progress

Simulation of actual VFE VHDL code using VFE technology specific SRAM

Modification of VFE code and simulation using FPGA SRAM

VFE chips incorporated in VHDL test-bench

Suggestions incorporated into VFE VHDL code

VFE chip plus test-bench running on Xilinx Spartan3E FPGA

Two chips plus test-benches fitted into single FPGA

- **25% of logic used**
- **83% of block RAM used**

Preliminary code for alternative pVFE implementation

Model slab to be finished soon and ready for tests

Networking and on/off-detector communication

Conventional network switches:

- testing ultimate performance of PCI Express - cope with high data rates, bundle system into fewer components.
- use PCI card: set-up so measurements can be made.
- series of tests done for other systems, PCI-X, ethernet, to be repeated.

Off- to on-detector communication:

- Monte Carlo simulation of radiation environment around FE electronics
- Evaluation of SEU effects on FPGAs

Off-detector receiver design

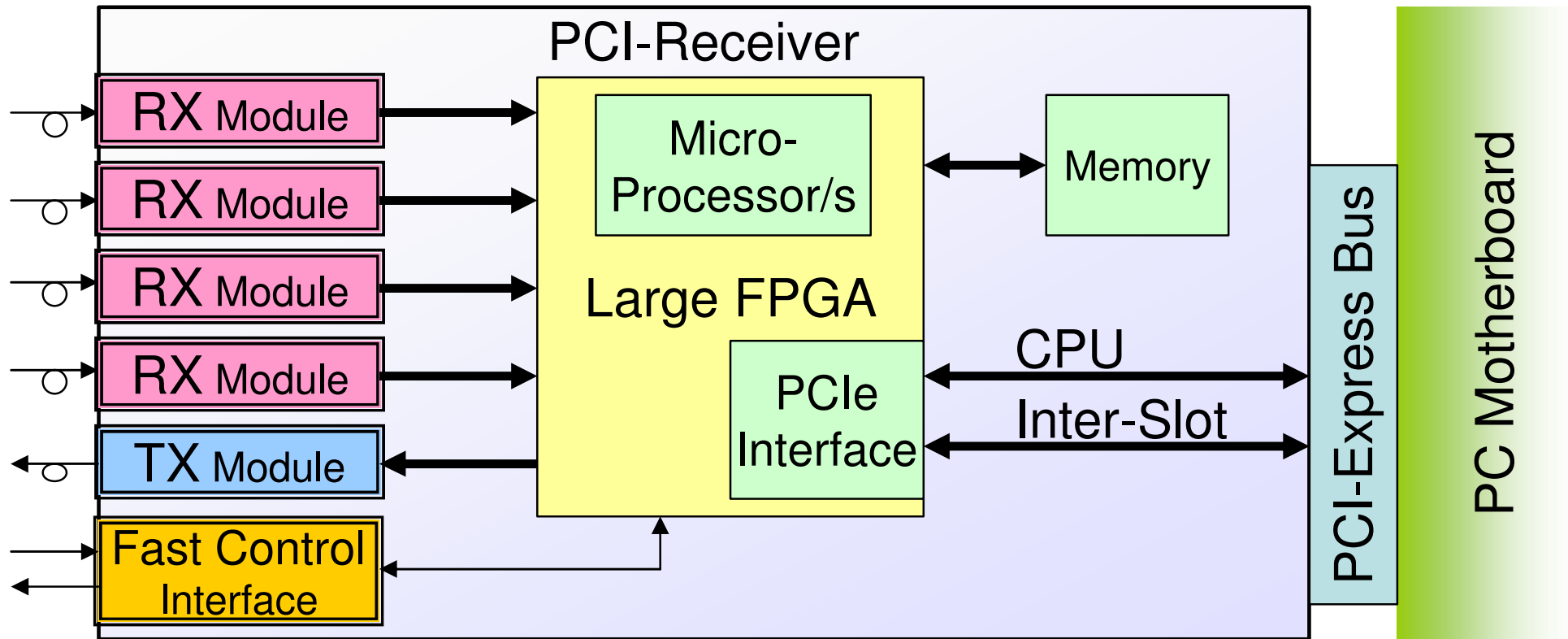

Custom design (using commercial components) and fabricate

Couple of rounds of iterations and final board ready

Off-detector receiver PCI card

Simpler to just buy(!) the cards



PCI cards - specs

Bought PCIe cards from PLD applications (<http://www.plda.com/>):

- **model: XpressFX100**
- **FPGA: Xilinx Virtex-4 FX100**
- **bus: PCIe x8 lane.**
- **Gbit optical and copper transceivers**

Hosted in computers in our labs.

Working on firmware and test software

PCI cards - tasks

Have a box diagram of a structure for passing data in such a system.

- **writing firmware for each box (several people: one person per box)**
- **collected in central repository**
- **first goal is to get data to be read into (and out) the host memory and measure the speed of throughput.**

PCI cards - box diagram of Stage 1

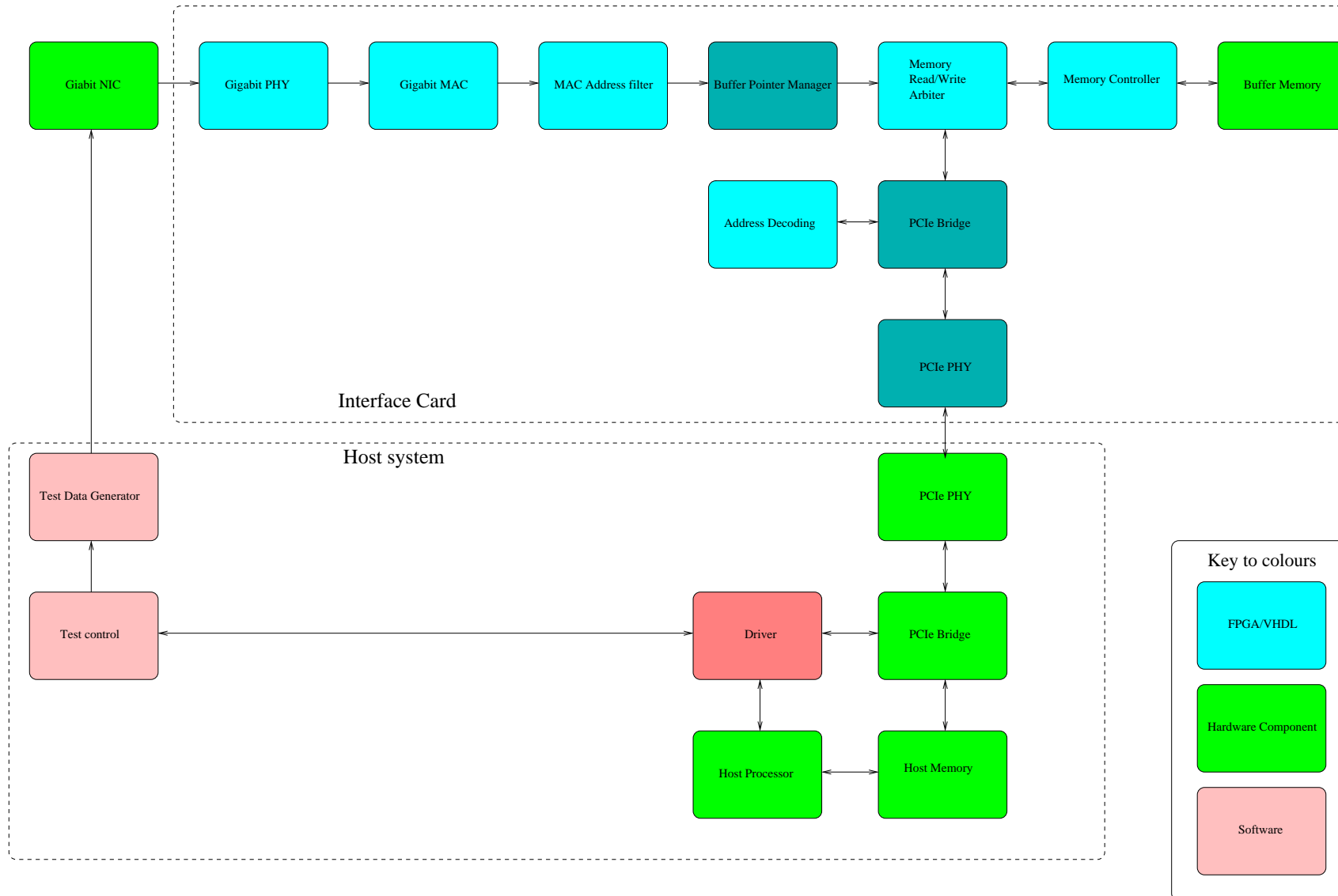

A (paper) model DAQ

Gives (order of magnitude?!) idea of scale of system. Useful for C/TDRs, can highlight problems.

- Assume ADC and thresholding done in 32-channel VFE, buffering in FE.
- Calorimeter/accelerator
 - Tesla 800 GeV bunch structure
 - 24×10^6 Si pads; 6000 slabs; 40 layers,
- Data size and rate:
 - Raw data 2 Bytes/channel, additional 4 Bytes/channel for a timing label
 - Threshold \rightarrow 100 \times reduction $\Rightarrow (24 \times 10^6 \times 4886 \times 6)/100 = 7.0$ GBytes or 1.2 MBytes/slab.
 - Buffering in FE \Rightarrow rate = 4.7 MBytes/s/slab.
 - Bundle half a tower, 20 slabs together, for a rate of 0.75 Gbit/s per fibre.

- **Components off the detector:**

- **300 fibres.**

- **assume a PCI card can receive 8 fibres \Rightarrow 38 PCI cards.**

- **assume a PC holds 2 PCI cards \Rightarrow 19 PCs.**

- **allowing 20% contingency (redundancy, faulty PCs)
 \Rightarrow 50 PCI cards and 25 PCs.**

A manageable system.